

GATE VALVE



105Q - 300PSI AWWA C509 Grooved-End Gate Valve

- Bolted Bonnet • Non-Rising Stem • Resilient Wedge • Grooved-End
- 300 PSI/20.7 Bar Non-Shock Cold Working Pressure
- Conforms to AWWA C509
- FBE Coated Interior and Exterior
- Maximum Operating Temperature 185°F / 85°C
- FM Approved & UL/ULC Listed

Material Specifications

PART	SPECIFICATION
1. Valve Body	Ductile Iron ASTM A 536
2. Resilient Wedge	Ductile Iron ASTM A 536 with EPDM Encapsulation
3. Wedge Nut	Bronze ASTM B 584 UNS C83600
4. Stem	Stainless Steel ASTM A 276 UNS S41000
5. Bonnet Gasket	EPDM
6. Bonnet Screw	Alloy Steel ASTM A 574M Zinc Plated
7. Bonnet	Cast Iron ASTM A 126-B
8. Stem Primary O-Ring	EPDM
9. Stem Thrust Washer	Stainless Steel ASTM A 276 UNS S41000
10. Gland Seal O-Ring	EPDM
11. Stem Ring Wiper	EPDM
12. Operating Nut Washer	Carbon steel Zinc Plated
13. Operating Nut Screw	Alloy Steel ASTM A 574M Zinc Plated
14. Square Operating Nut	Cast Iron ASTM A 126-B
14A. Handwheel (Optional)	Ductile Iron ASTM A 536
15. Stem Primary O-Ring	EPDM
16. Stem Seal Bushing	Brass ASTM B 16 UNS C36000

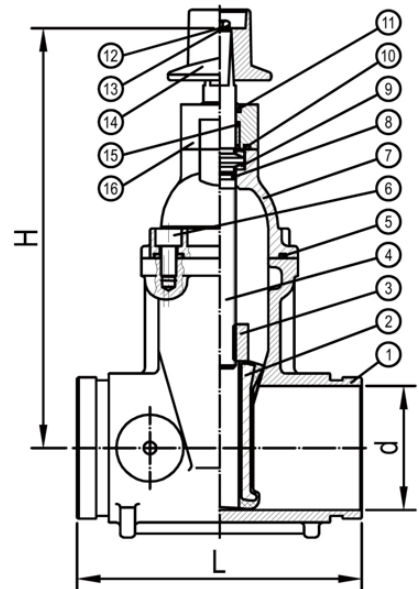

Dimension

Part Number	Size		L		d		H		Turns To Open
	In.	mm	In.	mm	In.	mm	In.	mm	
105Q-065	2.5	65	7.5	190	2.5	64	11.4	289	8.8
105Q-080	3	80	8.0	203	3.0	76	12.7	322	10.5
105Q-100	4	100	9.0	229	4.0	102	13.5	342	13.75
105Q-150	6	150	10.5	267	6.0	152	17.0	432	16
105Q-200	8	200	11.5	292	8.0	203	20.4	519	17.5
105Q-250	10	250	13.0	330	10.0	254	21.2	539	21.5
105Q-300	12	300	14.0	356	12.0	305	26.5	672	25.5

Note: Freezing Weather Precaution-Subsequent to testing a piping system, valves should be in an open position to allow complete drainage.

